

CUB FUN DAY AND CUBMOBILE 2010



Saturday, March 6, 2010
Camp Patten

2010 Cub Fun Day and Cubmobile

March 6

Camp Patten

Camp Patten is the place to be for fun and excitement! Cub Fun Day will give Cub Scouts some extra activities to do while they are not racing. Archery and BB Shooting will be available for Scouts to enjoy before and/or after they race! Archery and BB ranges will be open from 10:00 am until 2:00 pm.

As indicated below, registration for Cub Scouts is \$7.

Refreshments: A concession stand will be available from 10:00 am until 2:30 pm.

Registration fee: \$7 per Cub Scout (includes participation in Cub Fun Day Activities) Register Scouts as a den using the registration forms in this packet.

Check-in times:

Tiger Cubs will race at 9:00 am.

Wolf Cubs need to be registered by 11:00 am.

Bear Cub Scouts register at 1:00 pm.

Cubmobile vehicle check-in will be open for 1 hour prior to race time.

Each Den Needs:

1. One car per eight boys in each den or pack, max. eight boys per team (all boys in a team will race with the same car) If there are ten boys in your den coming to Cubmobile, you will need two cars – two teams of five.
2. Helmet, Elbow Pads, and Knee Pads (one set per den)
3. There has to be at **least** two racers per den.

Rules:

All cars are to be made with recommended materials.

(Nothing can be added to weigh the car down)

No Fred Flintstone driving (this means feet and hands stay on the cubmobile)

Judging the Race:

All racers will race 2 times down the lane and will be timed. The average time per boy per den will determine the winners. Racers not completing the course to the finish line will receive a penalty added to the slowest time in the den.

Pack Camping:

Packs are welcome to camp at Camp Patten for the weekend. There will be no official program activities except for the Cubmobile and BB and Archery ranges (10:00 – 2:30).

Please duplicate this sheet as needed

2010 CUB FUN DAY/CUBMOBILE RACE

Registration Form

(Please Register by Fri., February 26)

Pack _____ Rank _____
District _____

<i>Scout</i>	<u>\$7 Fee</u>
1.	
2.	
3.	
4.	
5.	
6.	
7.	
8.	

2010 CUB FUN DAY/CUBMOBILE RACE

Registration Form

(Please Register by Fri., February 26)

Pack _____ Rank _____
District _____

<i>Scout</i>	<u>\$7 Fee</u>
1.	
2.	
3.	
4.	
5.	
6.	
7.	
8.	

Cubmobile Specs and Parts

- ❑ See the illustration for building materials and hardware.
- ❑ Wheels may not exceed 10 inches in diameter or be less than 7 inches in diameter.
- ❑ All wheels must be equipped with solid (non- pneumatic) rubber tires.
- ❑ The car frame is made from 2-by-4 construction lumber.
- ❑ The car frame has a maximum of 52 inches. (Not to exceed this in length)
- ❑ The wheelbase has a maximum of 4 feet.
- ❑ The width of the car frame will not exceed 28 inches
- ❑ Use ½ inch bolts to hold the frame. Screws are a second choice. Nails are **not** suitable.
- ❑ All cars must have a seat with a braced backrest so the boy can comfortably steer with his feet. *Adjustable seats are **required** due to boys being different heights.*
- ❑ Cars must be equipped with an adequate safety belt securely fastened to the frame of the car. Seat belts should be of automotive or aircraft type (heavy duty).
- ❑ Steering is done with the feet, placed on the front axle
- ❑ The rope on the front axle should not be used to steer but to steady the car during driving
- ❑ If threaded axles are used, the nuts must be secured with cotter pins, locking nuts, or tie wires.
- ❑ Cars must be equipped with a hand brake. Its rubbing surface must be faced with a rubber material such as a strip of an old tire. This will stop the car when dragged on the ground.
- ❑ During the race the 2-by-4-inch blocks fastened ¼ inch(.25) or less from the centerboard will limit the turning radius. See illustration. Please secure blocks with at least two bolts per block. ¼ inch or less space for center axle to blocks will be strictly enforced.
- ❑ Steering limiter blocks should be made of durable material as they are prone to splitting and being torn loose!

***Please note on the diagram the addition of required footrests so that the Scouts' feet do not hit the ground.**

****It is suggested that you bring spare parts (i.e., front and rear axles) in case of breakage.**

Remember, your most important concern in building this vehicle should be:

THE SAFETY OF THE DRIVER!!!!!!

For seat details, see next page.

Cubmobile Specs and Parts

7-8" Diameter wheels from lawnmower, wagon, tricycle, barbells, etc.

Reinforce this area with glue, screws, extra bolts, etc. The joint at the rear axle tends to work loose fast and this can cause steering problems!

Use these type fasteners. Nails will not hold.

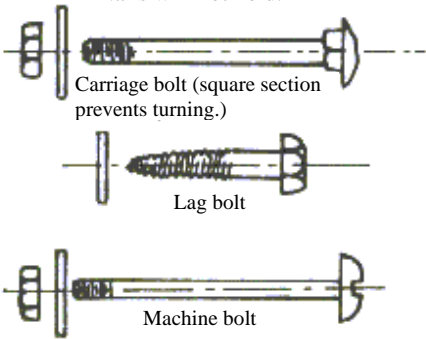

Carriage bolt (square section prevents turning.)

Lag bolt

Machine bolt

Footrest, to prevent feet from hitting ground

Frame: 2 x 4 52" long

Steering bridle: 1/4" nylon rope

Axles: 2 x 4 28" long

Front axle attachment detail

Safety blocks to limit steering angle.

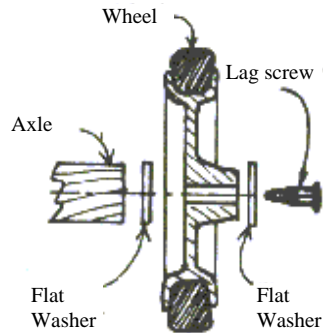

Wheel

Lag screw

Axle

Flat Washer

Flat Washer

Bolt seat to frame with 3/8" carriage bolts, 2 places, to achieve adjustable seat

Plywood brace: one each side

Flat Washer

Drill holes

Machine Bolt: 1/3", 4" long

2 Flat washers

First axle

Washer

Nut

Second nut tightens against first to lock

Footrest

Nail strip of old tire to brake

Brake

15 1/2"

12"

2 Carriage bolts 1/2", 4" long

48" Wheelbase

Detail of seat construction

